

Basic Thermoset Part Design Suggestions

The decision on which thermoset molding method should be used to produce a given part is normally made by the end-user and the molder. It is also advisable that while the part is still in the design stage, the proposed design be discussed with the material supplier. Items for discussion should include but not be limited to; method of molding, gate location, ejector pin location, tolerances, parting line location and part finish. Most PLENCO thermoset molding compounds can be formulated for use in any of the thermoset molding processes. Regardless of which thermoset molding method is to be used, certain basic design fundamentals are suggested. Product design engineers should consider these fundamentals in their design to help achieve a quality part at an economical cost, both in terms of the price of the material and the mold itself.

Parting Line

When designing a part, consideration should be given to the location of the parting line. To mold parts with minimum flash at the parting line, it is important to be sure that the force and the cavity fit together and seal properly. If possible, **stepped** or **contour parting lines** should be avoided, as telescoping mold sections add to the mold cost, increase mold maintenance, and can add to the finishing costs of the parts.

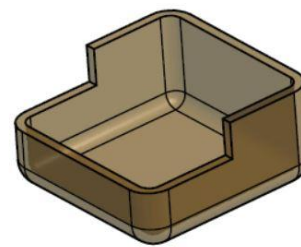
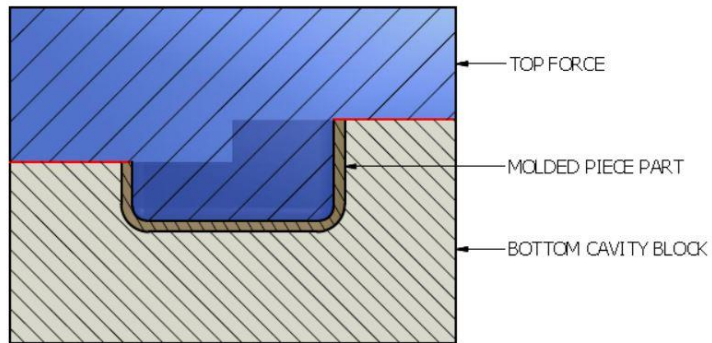

STEPPED PARTING LINE
MOLDED PIECE PART

If the parting line is located on a sidewall of the part, it is nearly impossible to construct a mold without a slight mismatch between the force and the cavity. This is easier to accomplish on circular parts but difficult to accomplish on rectangular or odd shaped parts. If it is necessary to locate the **parting line on a sidewall**, a definite mismatch of 0.010" - 0.015" (0.25 mm - 0.38 mm) between the force and the cavity may be incorporated into the part design.

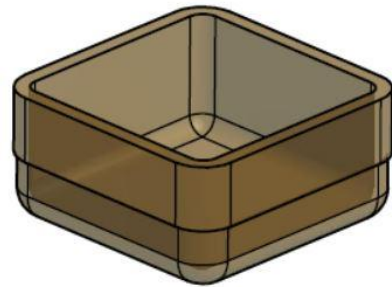
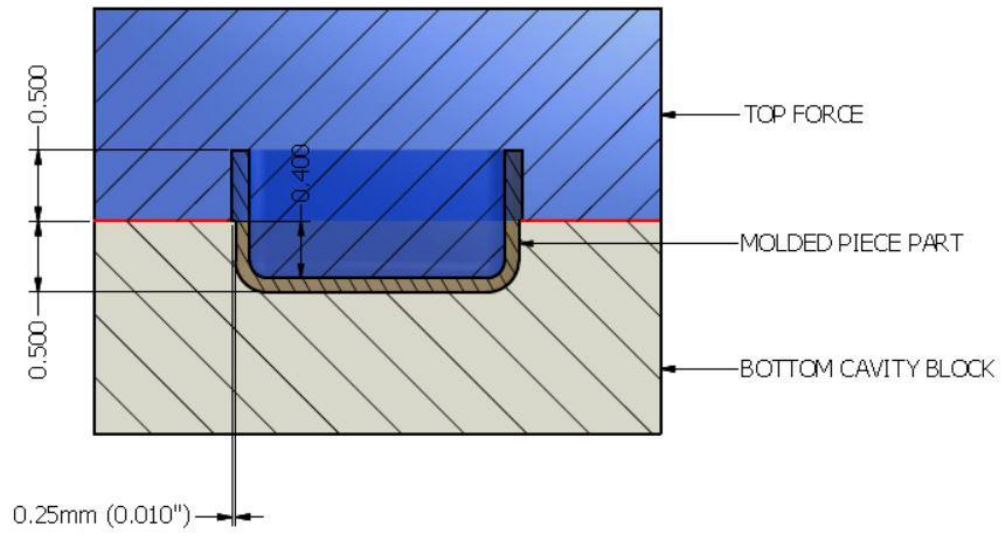

MIDPOINT MISMATCHED PARTING LINE
MOLDED PIECE PART

Another approach is to add a 0.010" (0.25mm) **bead** around the part at the parting line.

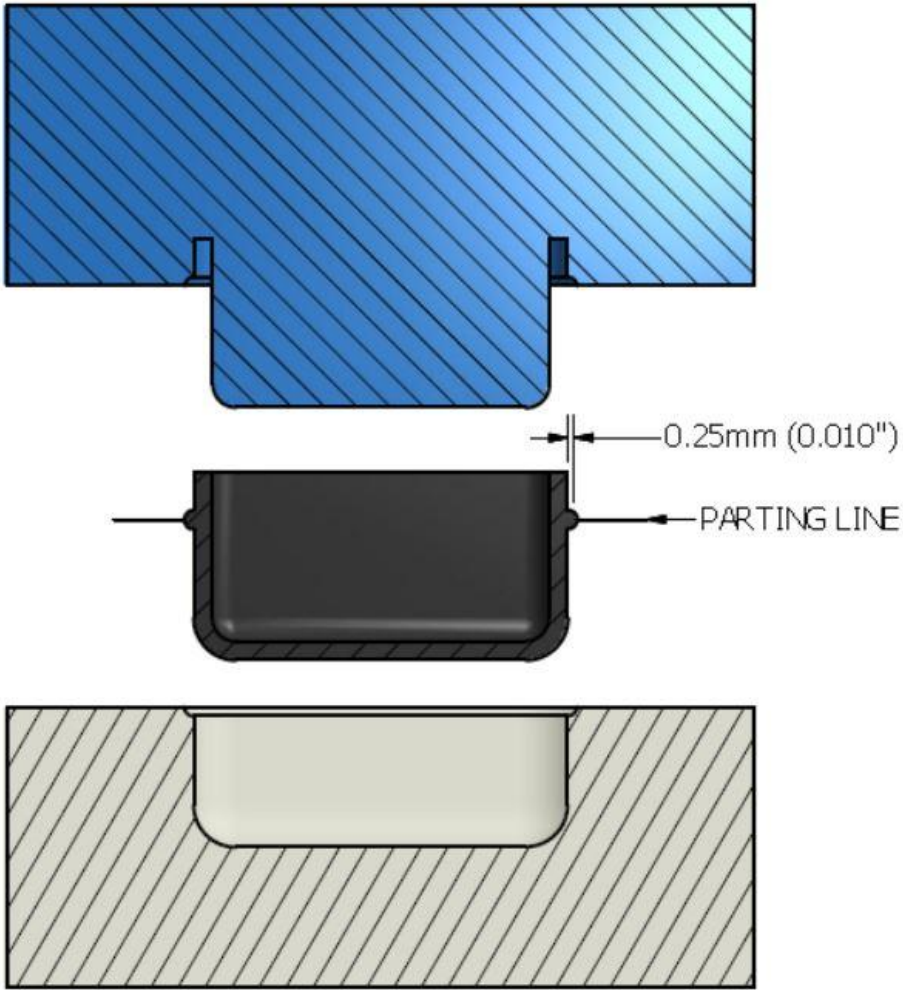

BEADED PARTING LINE

If **chipping** or **breakage at the parting line** is a potential problem, designing with a 0.015" - 0.030" (0.4mm - 0.8mm) radius at the parting line can be helpful in eliminating or reducing this problem.

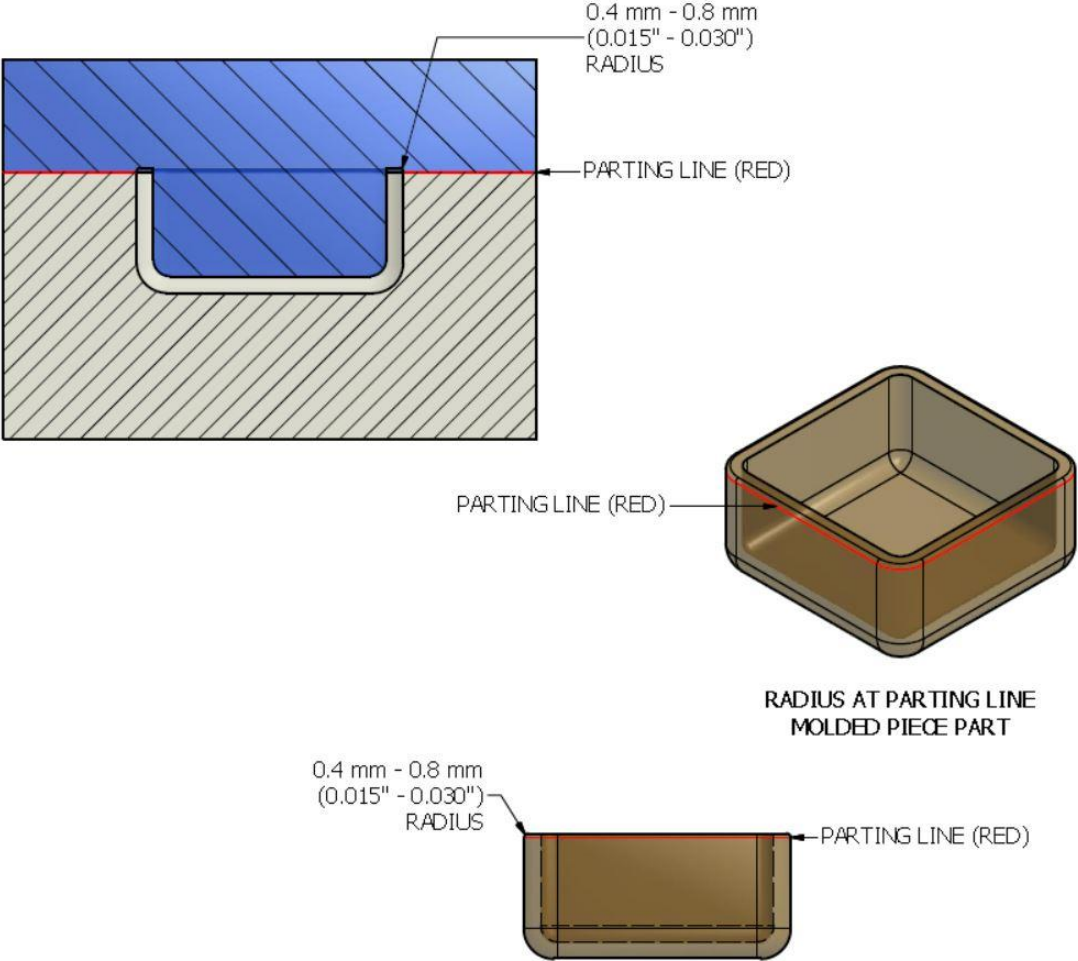

Parts with **vertical decorations** or **flutes** should stop short of the parting line by about 0.080" (2 mm) to permit ease of flash removal.

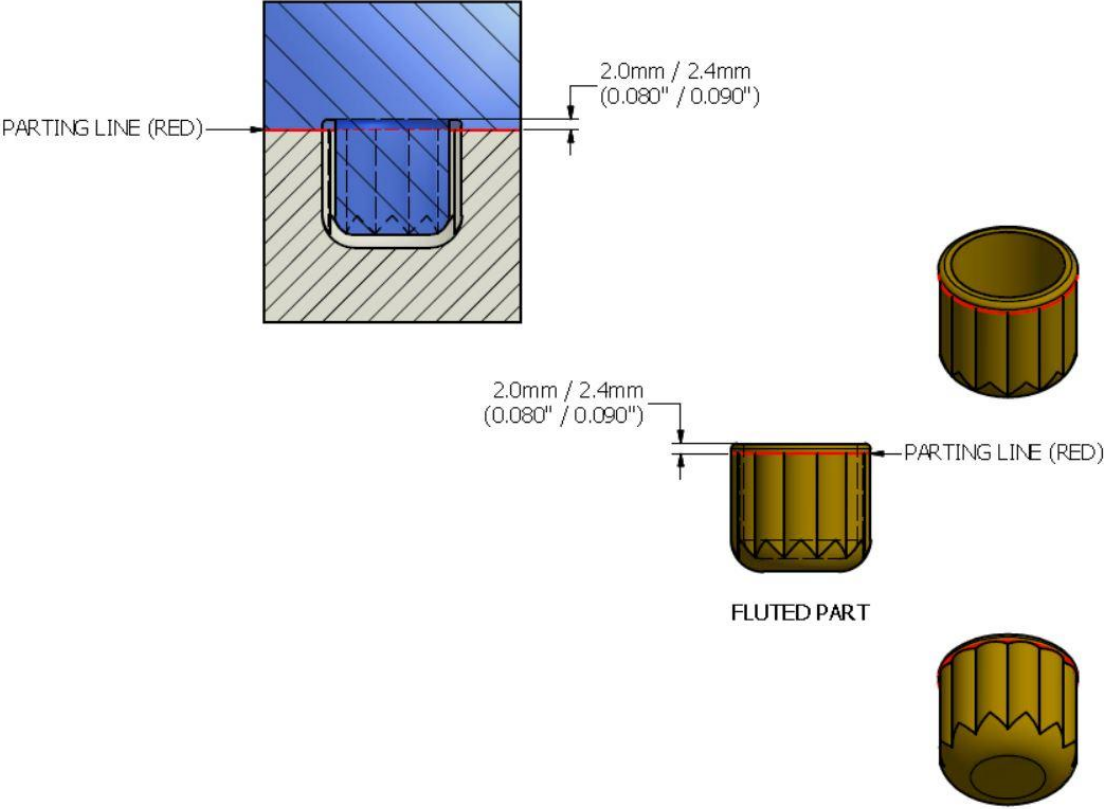

Side Cores

When designing a part, the designer needs to keep in mind that any mold action that obstructs or blocks the ejection of the part from the cavity is referred to as an **undercut** and will require special mold construction to permit the molding of the part. Therefore, a part should be designed without undercuts whenever possible. If it is necessary to have an **external undercut**, the mold can be designed using **external side cores** that can be activated by hydraulic cylinders or cam slides. Another method of molding in an undercut is through the use of **removable mold sections**. Because of the cost and the greatly reduced production rates achieved when using loose cores, this method is rarely used today. It should be noted that adding side cores to a mold increases the initial cost of the mold and will also increase the mold maintenance costs. Side cores can also limit the number of cavities within a mold. Piece part costs may increase due to reduced production rates, higher mold maintenance cost and the need for additional finishing because of the flash created where the side cores meet the force.

Internal undercuts are much more complicated and usually require the use of removable mold sections, loss cores, split cores or side cores that are activated by cam slides or hydraulic cylinders. In some cases, it is necessary to machine the undercut in a secondary finishing operation.

If it is necessary to have a through **side hole**, the mold can be designed to permit the hole to be produced without needing to have side cores. This may require altering the part design, which would require the approval of all parties involved.

EXAMPLE OF TELESCOPING MOLD SECTIONS TO FORM A MOLDED HOLE

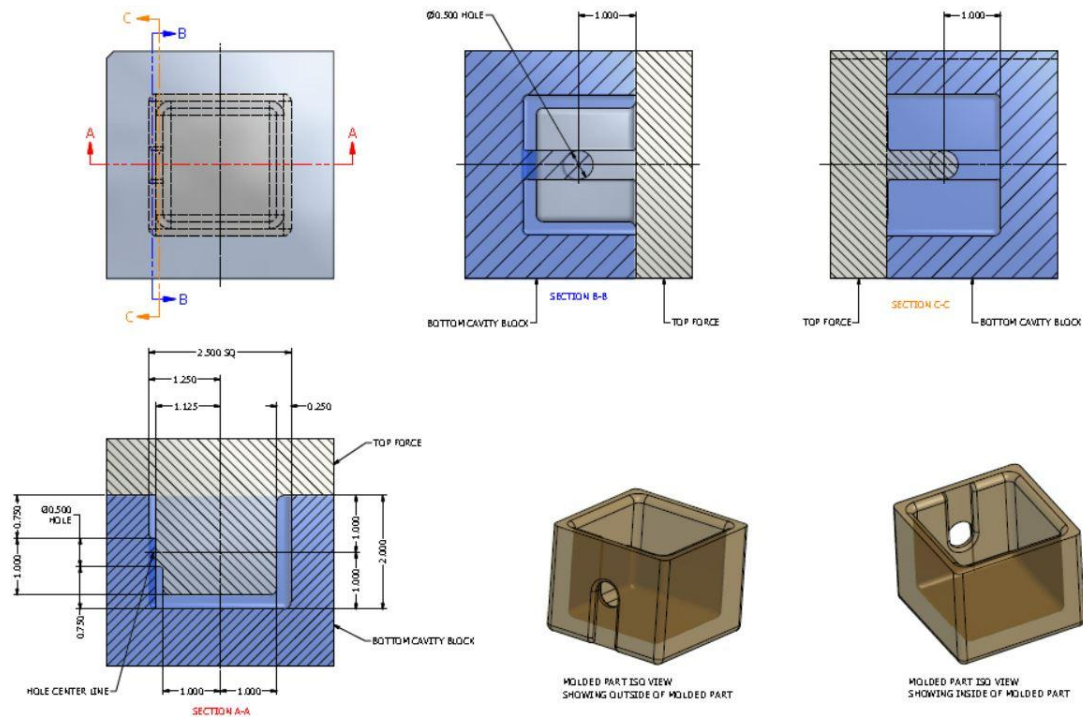

Corners

Sharp **internal corners** are to be avoided whenever possible. These can be the source of cracks, part weakness and can also affect how the part fills. Generally, the larger the radius on an internal corner the better. The minimum radius for an internal corner should be 0.030" (0.76 mm"). However, if a radius of 0.030" (0.76 mm") is not possible, a radius of 0.010" (0.25 mm) is better than no radius.

It is also a good idea to radius the **external corners** of the parts, since it reduces the likelihood of the parts getting chipped or broken during handling. The guidelines for a radius on an external corner are the same as those listed in the previous paragraph for internal corners. Here too the larger the radius, the better.

Wall Thickness

It is a good practice to avoid designing a part with very **thin cross-sectional areas**. Thin cross sections are prone to cracking and breaking during handling and are likely to have molded-in stresses which can cause warpage and weak parts. These areas will

also restrict material flow and tend to be the last places to fill. As a result, air and volatiles are trapped in these areas which may cause staining on the mold surface.

We typically suggest a minimum wall thickness of 0.080" (2.0) mm for all of our thermoset materials. However, there are many thermoset applications that have been successfully designed with even thinner walls. A couple of reasons for this are the overall part design and the stresses the walls will have imposed on them during use. Therefore, each application needs to be reviewed to determine an acceptable minimum wall thickness.

Thick cross-sectional areas should also be avoided because they will become the limiting factor in the curing of the part. They also can cause part warpage due to their having a different shrink rate than the remainder of the part.

Designers should endeavor to design all parts with **uniform wall sections** to avoid the problems of cracking, breakage and warpage mentioned above. In addition, a uniform wall section is desirable from the standpoint of cycle times. A part with a uniform wall thickness of 0.090" (2.3 mm) is going to cure faster than the same part with walls that are 0.100" (2.5) mm in some places and 0.080" (2.0) mm in other areas.

Draft

Draft should be provided on all walls parallel to the line of draw. If the part is to remain on the force, the **draft** on the cavity should be larger than that on the force (i.e. the draft on the cavity is 1-1/2° while the **draft** on the force is 1/4°). If the part is to remain in the cavity, the draft will be the opposite. It is suggested that the **draft angle** for most parts be 1° to 2°. In cases where dimensions need to be held to a very tight tolerance or when using glass filled or other low shrinkage phenolic molding compounds, a lesser **draft angle** can be used. Parts molded with thermoset polyester molding compounds need more draft because of their easily scratched softer surface. More **draft** means less drag on the surface of the parts and therefore less chance for the parts to be scratched or marred.

Matte or grain finishes should be avoided whenever possible on sidewalls which are in the direction of the removal of the part. The reason for this is texturing on these sidewalls can create an undercut and lock the parts into the mold. If a textured side wall is required, the texture will need to be very shallow and the part will need a generous **draft**. It is suggested that a **draft angle** of 2° per each (0.001") 0.025 mm depth of texture, be used for textured sidewalls.

Ribs

Ribs are usually added for strength reasons, but they are also added to help decrease warpage or to act as internal runners to improve material flow to areas that might be difficult to fill. **Ribs** should be less than half the thickness of the wall to which they are attached. There should also be a generous radius at the junction between the wall and the rib. This is done to help prevent the appearance of "shadow marks" on the part surface opposite the ribs. As a rule, the **rib height** should not exceed 3 times the wall thickness to which it is attached and be designed with generous draft on both sides.

Bosses

Bosses are protruding studs or pads used for reinforcement of holes or in the part assembly. The **height of the boss** should be no more than twice the diameter. The boss should be designed with a generous draft and also a generous radius at its base.

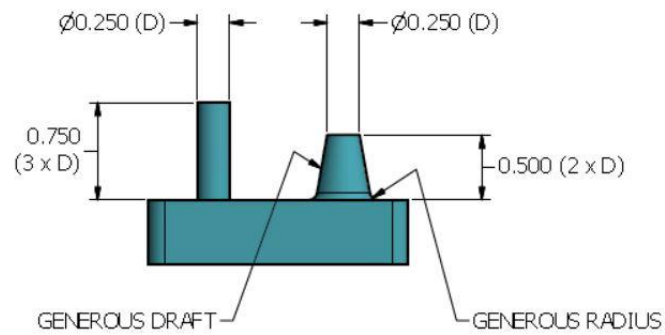
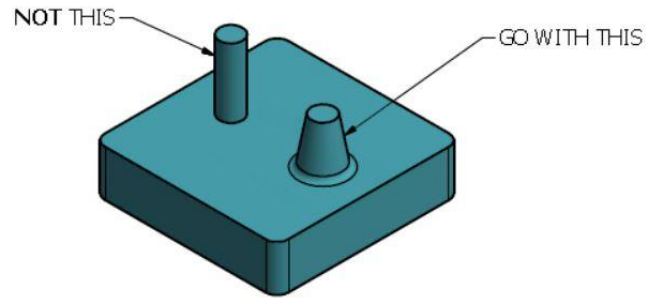

If it is absolutely necessary to have a **boss with more height**, three or four ribs can be added to the outside diameter for strength. The ribs should also aid in part removal and in flowing material flow material up into the end of the boss. There should also be a generous radius at the base of the boss.

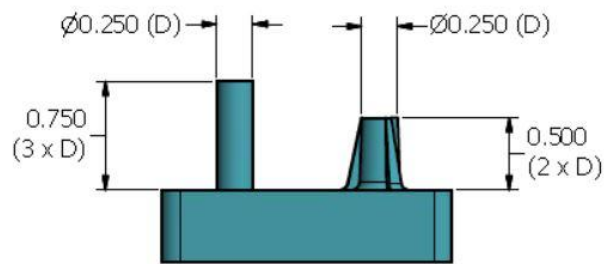
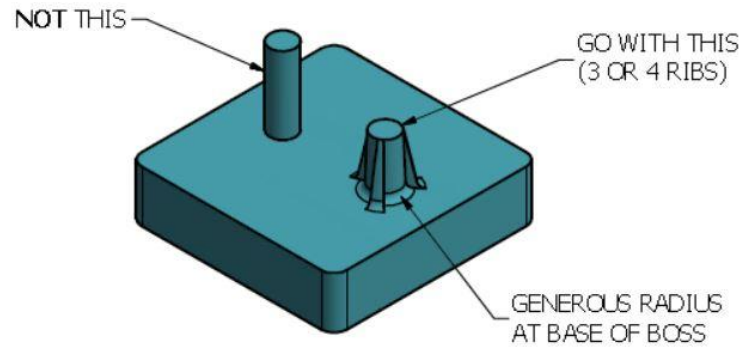

If a **boss** is designed **with a hole in the middle**, the diameter of the boss should equal 3 times the diameter of the hole. This applies to bosses with holes up to 0.500" (12.7 mm) in diameter.

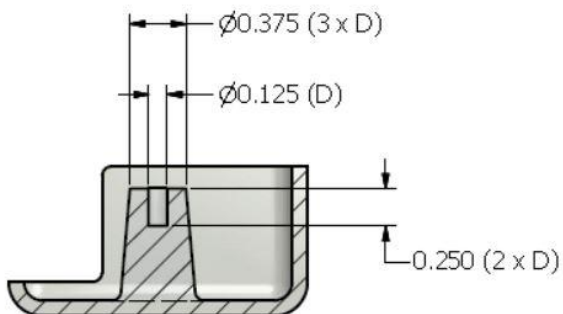

MOLDED PIECE PART
CORED BOSS DESIGN

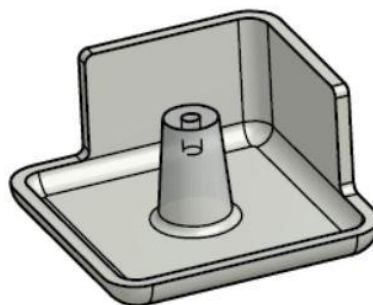

MOLDED PIECE PART
SIDE WALLS REMOVED TO
ILLUSTRATE BOSS DESIGN

Holes

Through holes or blind pockets should be formed by mold inserts that can be easily replaced if they are damaged or worn. Because the pins forming the holes are subject to pressures that may cause them to bend or break, we suggest that pins for **cored holes** or **blind pockets** be limited in length to 2 times the diameter of the pin. If the **core pin is piloted** into the stationary half of the mold, longer through holes can be achieved. Piloting the core pins into the other half of the mold will change the direction of the flash so it does not affect the diameter of the hole.

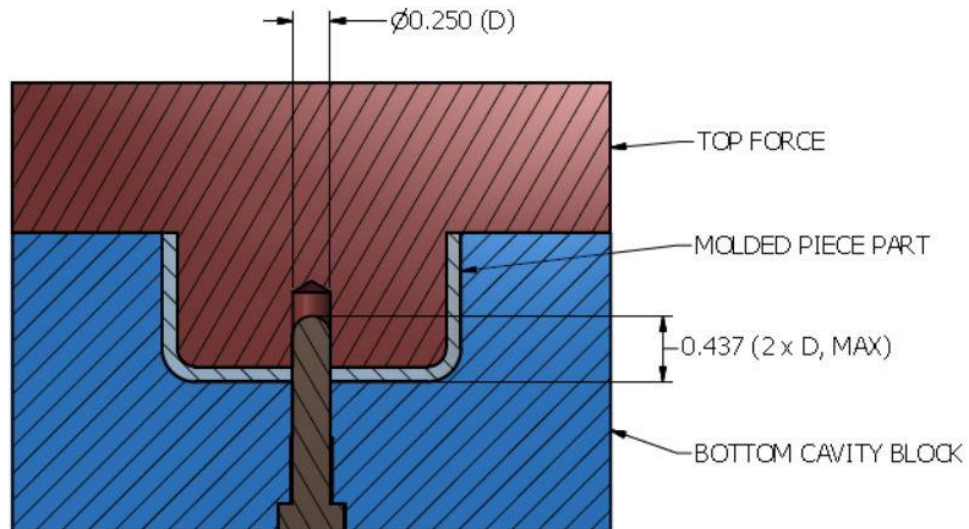

PILOTED CORE PIN HOLE

Very **long cored holes** can be made by having core pins on both halves of the mold that butt together in the middle. When using **“butt pins”**, it is necessary for one of the pins to be larger in diameter than the other pin. This will eliminate the mismatch of the two pins. We normally suggest that the larger pin be at least 0.010" (0.025) mm bigger than its counterpart.

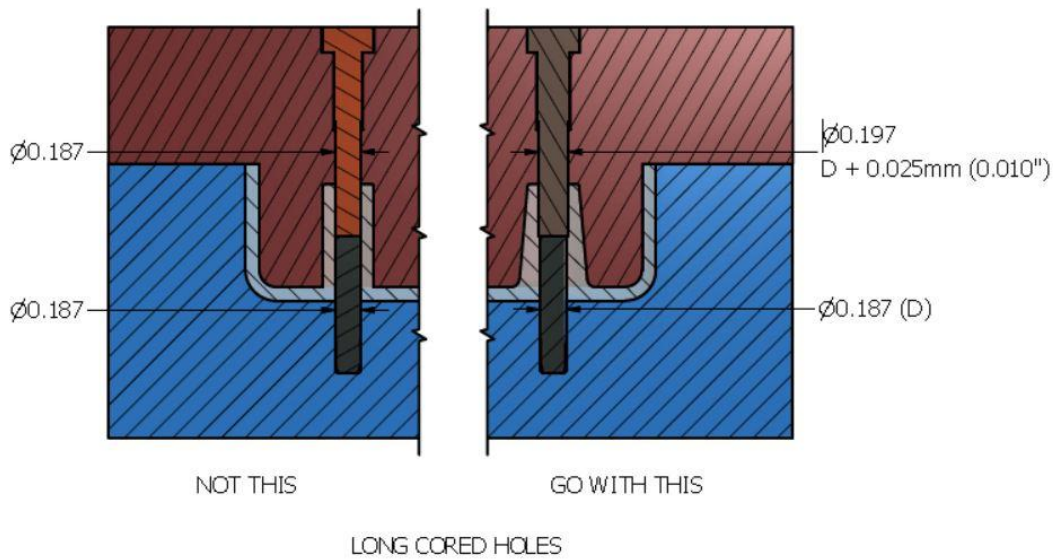

It is important to keep in mind that when the material is forced to divide and flow around a core pin or any obstruction, a **weld or knit line** may develop on the opposite side of the obstruction as the two fronts of material join. Knit lines are typically much weaker than the main body of the part and it is a good idea to try to direct knit lines so they don't affect the overall strength of the part. This is generally accomplished by changing the location of the gate which forces the knit line to form in an area that will be subjected to lower stresses.

Threaded Holes

Many thermoset parts are assembled with screws. Threads can be formed in parts in a number of ways. The threads can be molded into the part with threaded cores, they can be added in a post-mold tapping operation or molded in metal inserts can be used. In some cases, self-tapping screws are used in the assembly.

A common method used to produce **threaded holes** is to mold removable inserts into the parts. When these inserts are removed, they leave a tapped hole in the part.

Shrinkage of the material must be considered in all **three** axis's when designing the removable mold insert.

When using taps to form internal threaded holes, we suggest using carbide taps. Because phenolic materials can be abrasive, carbide taps will provide longevity over high-speed steel or nitrated taps.

If the part is to be molded in a **polyester material**, the best method of obtaining a tapped hole is with the use of **molded in metal inserts**. We do not suggest tapping holes in polyester materials due to the soft surface of the material, as the threads are not cut clean, and tend to crumble readily. Also, **molded in metal inserts** should be used in cases where the part will be assembled and disassembled many times. It is important to remember that the **wall thickness** around the threaded hole or around the insert should be equal that of the insert or the thread diameter, otherwise you may experience some cracking when the parts shrink.

In materials that have a hard surface like phenolics and melamine-phenolics, it is possible to use **self-tapping screws** for assembling parts that do not need to be frequently assembled and disassembled. Wire type self tapping screws work very well in thermoset materials. The design information put out by the screw manufacturer will specify the diameter and depth of the hole required their screws. It is important to remember that when a boss contains a cored hole for a self-tapping screw, the O.D. of the boss needs to be 3 times the diameter of the cored hole.

Cooling Fixtures

Absolutely flat surfaces or straight sidewalls are very difficult to mold due to the shrinkage of the materials. **Warpage** is roughly proportional to the amount of shrinkage of the material. That is why an injection flow material will usually have more warpage problems than a transfer flow of the same product. Flatness tolerances should allow for some warpage due to material shrinkage. To hold a part flat it will be necessary to use **“cooling”** or **“clamping fixtures”**. These are devices that mechanically hold a part fresh out of the press in a prescribed position until it has cooled enough to stay in that position. When using **cooling fixtures**, it is important to load the part into the fixture as fast as possible. Taking longer than 10 – 15 seconds to load the cooling fixture may result in parts that the fixture can't keep within the flatness tolerance.

Summary

Each part design will present its own unique challenges when it comes to designing a mold to produce the part. The design suggestions that have been presented address some of the more common problems that molders, and end users face when designing a part that is to be molded from thermoset materials. Before starting to build a mold to produce a new part, the proposed part and mold design should be fully discussed by the end user, the molder, the mold maker and the material supplier. This type of discussion can reveal possible problems so they can be dealt with before the mold is built. Remember, it's much easier to change the part design or the mold design before starting to build the mold, than after it is in the press and ready to mold the first samples.