

Thermoset Compression Mold Design Tips

When designing a mold for a compression molded part, it is important to keep in mind that the goal is to produce quality parts in as short a cycle as possible with a minimum of scrap. To achieve these goals, you will need to design a mold that has uniform mold temperature, and is properly vented.

Mold Heating

The optimum **mold temperature** is when each half of the mold is within $\pm 5^{\circ}\text{F}$ (3°C) for all locations when the mold is heated by oil or steam. Molds that are heated with electric cartridge heaters may vary by as much as 10°F (6°C). A mold with uniform temperature will fill easier, produce parts with less warping, have improved dimensional stability and a more uniform surface appearance. Achieving a uniform mold temperature is dependent on the method of mold heating.

A mold that is **heated** by **steam** or **oil** will have a more uniform mold temperature than a mold heated by electric cartridges because the heat source maintains a constant temperature. However, oil as a heat source is only about half as efficient as steam. Therefore, when using oil to heat a mold, it is necessary to set the oil temperature higher than the desired mold temperature. Please be aware of the safety and environmental concerns involved with all forms of mold heating.

It is more difficult to maintain a uniform temperature when heating with electric cartridges because the cartridge heaters are constantly cycling on and off.

To determine the amount of wattage needed to heat a mold, the use of the following formula may be helpful: **1.25 – 1.5 kilowatts for every 100 lbs. (45 kg) of mold steel**. Note: This formula typically will allow the mold to be heated to molding temperatures in 1 to 2 hours.

Locating a heater on the centerline of the mold is not recommended, because the center of the mold is normally hot enough without adding any additional heat. Typically, the **cartridge heaters** are located in the support plates, with a distance of 2 ½" (64mm) between heater cartridges. **NOTE:** Deep draw molds may need to also have heaters in the retainer plate. There should be a minimum of one **thermocouple** to control each half of the mold. In larger molds, it is recommended to have more than one thermocouple in each mold half. This will result in better control and more uniform mold temperatures. The **thermocouples** should be located in the "A" and "B" plates, between two heaters if possible and at a distance of 1-1/4" to 1-1/2" (32mm – 38mm) from the closest cartridge heater. This distance is to be measured from the edge of thermocouple hole to the edge of the cartridge heater hole. The distance from the thermocouple to the cartridge heater is important because if a cartridge heater is too close, it will cause the thermocouple to turn off the heat before the mold is at temperature. A heater that is too far away from the thermocouple will result in a mold that overheats and then gets too cool. Likewise, it is not a good practice to position a thermocouple so it senses the external surface temperature of the mold. If possible, it should be located a minimum of 1-1/4" to 1-1/2" (32mm – 38mm) inside the mold, preferably against the cavity block.

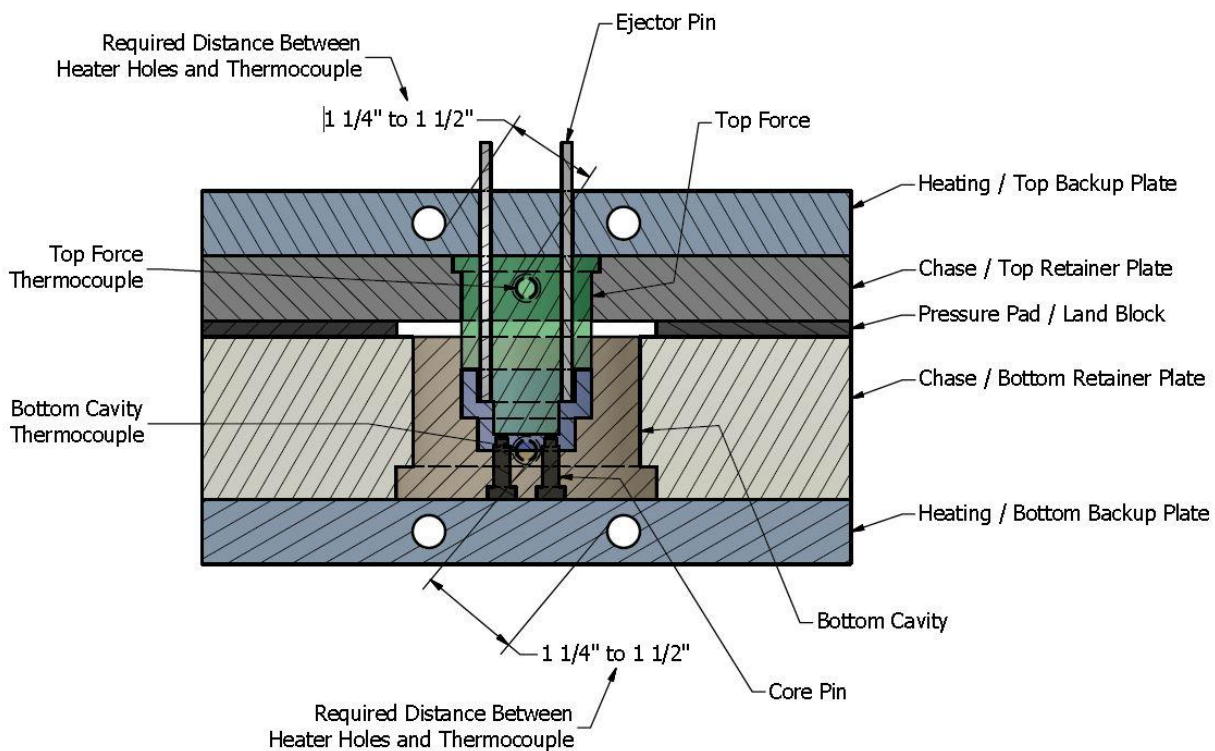

Venting

When molding thermosets, the polymerization process that takes place produces volatiles which along with the air already within the cavity chamber can become trapped and superheat to 700F° - 800°F (375°C - 425°C). If the gases are not allowed to escape through vents, they may oxidize the lubricants leaving **burn marks** on the part. The vents allow the volatiles to escape to atmosphere. In addition to visual problems, improper venting will result in parts that cannot be filled, have dimensional problems or have less than the expected physical and/or electrical properties.

The first question that has to be addressed is **vent location**. It is important that all vents must lead to the atmosphere otherwise the vent will be useless. Unless the part geometry shows some obvious locations for vents, a brief molding trial should be conducted to observe where the gas voids occur. Whenever possible, **vents** should be located in the movable half of the mold wherever a gas void or knit line is seen on a part.

Vents for phenolic parts should be approximately ¼" (6 mm) wide and 0.003" - 0.0035" (0.08 mm - 0.09 mm) deep and **vents for polyester** parts should be approximately ¼" (6 mm) wide and 0.002" - 0.0025" (0.05 mm - 0.06 mm) deep. The width is not as critical as the depth. The vents should initially be cut to the minimum depth recommended for the particular type of molding material that will be processed in the mold.

Of equal important to the location and depth of the vents is **vent length**, which is the distance from the part that the vent maintains its depth. The vent should be approximately 1" (25 mm) long to allow pressure to build in the cavity after the material in the vent cures. After this point, the vent can be relieved to a depth of 0.01" - 0.02" (0.25 mm - 0.50 mm). To help the vent stay with the part, the corner of the vent at the part edge can be radiused or chamfered.

A molding trial is then made to determine if the mold will completely close at this minimum vent depth. If the mold is held open because the vents freeze off sealing any excess material in the cavity, then the vents need to be increased in depth until the mold is able to completely close. It is important not to make the vents too deep because they may not seal and as a result, internal cavity pressure will be low and the part(s) may have dimensional problems or have less than the expected physical and/or electrical properties.

It is sometimes necessary to vent "dead" areas of the mold with **vented ejector pins**. Before adding the vents, an ejector pin should fit the hole in which it will operate within 0.001" (0.025mm). A flat is then ground on the diameter no deeper than 0.005" (0.013mm) for a distance that will take the vent 1/8" (3mm) below the fit length of the pin. Normally, the fit length should be 1/2"- 5/8" (13mm-16mm) long. (See drawing below). In addition, the stroke of the ejectors should be long enough for the entire vent plus 1/8" (3mm) to come up above the bottom of the cavity. This is so the vent can be self- cleaning or so an operator can blow the flash off the pins.

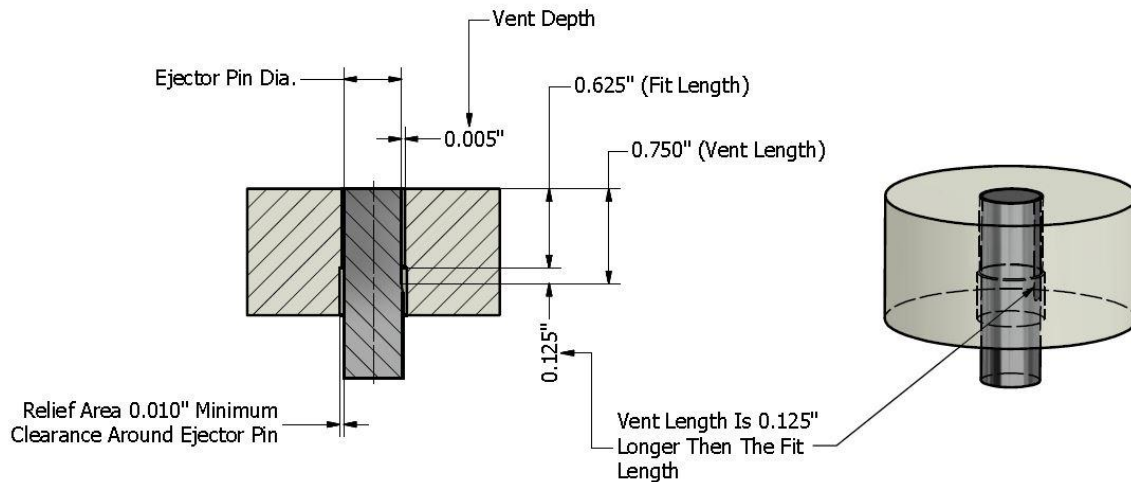

Something that is often overlooked in venting is the polish. It is recommended that all vents be **draw polished** in the direction of flow to at **least** the same finish as the cavities and cores. They should be polished for their entire length including the relieved distance. If a mold is to be chrome plated, all the **molding surfaces** should be polished and plated including the vents.

Additional Mold Tips

Individual Cavities and Cores - In nearly all molds, the use of **inserted cavities** and **cores** is encouraged. The primary reason for this is in the event of an individual cavity or core being damaged, that particular cavity can be removed from the mold and repaired while the rest of the mold is put back into service. Having individual cavities also allows for insert changes that make it possible to run multiple versions of the same basic part simultaneously. When the parts are very small and there is a large number of cavities, individual cavity inserts might not be feasible. In those situations, we would suggest using cavity inserts of 3 or 4 cavities. The materials most commonly used for cavity inserts are H-13 and S-7. Both of these materials will harden to Rockwell 52 to 54 and can be polished to produce an excellent surface finish on the parts.

We also recommend that the force have a minimum engagement of 0.750" (19.050mm) into the cavity.

Clearance Between The Force and Cavity Mold Halves

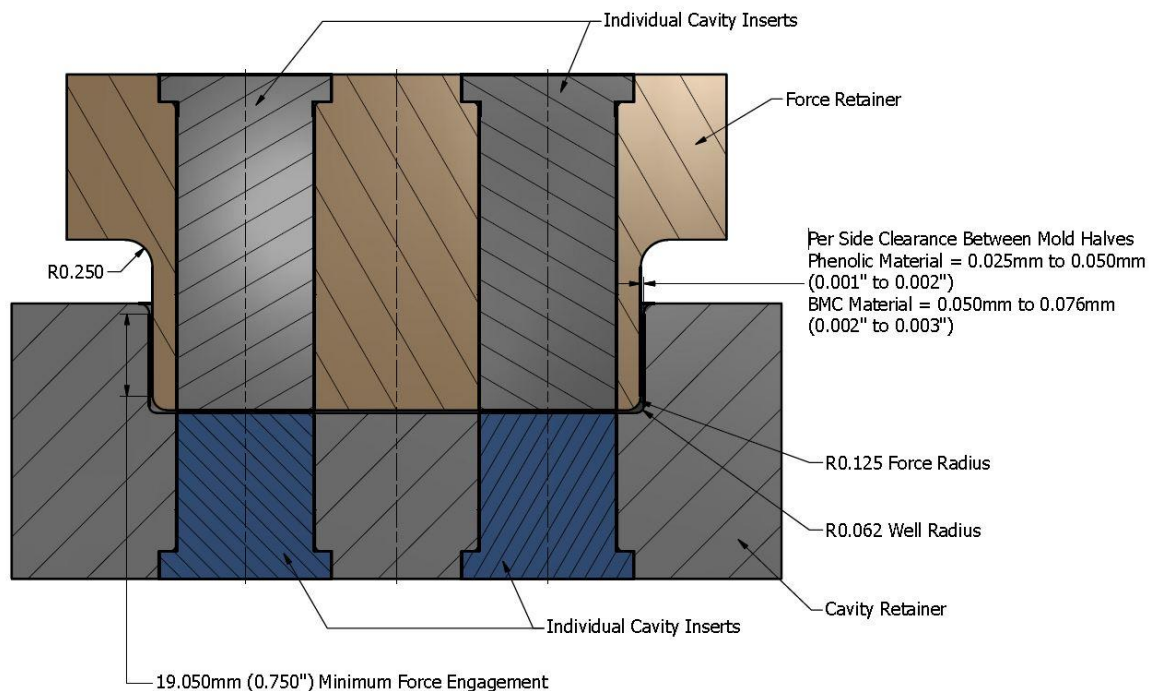

Ejector Pin Location and Design

Without ejector pins it is usually not possible to remove the molded part from the mold. The placement of the ejector pins is almost as critical as the location of the gate. The pins should push the part out of the mold without distorting it and without leaving an objectionable mark on the part. A secondary reason for having ejector pins is to aid in the venting of the mold.

Ejector pins should be located in the deepest points of the cavity or core. We specifically suggest that ejector pins be located on the deepest points of ribs and bosses. If ejector pins are not located correctly, the part has to be "pulled" out of the deeper areas or the mold. Parts that have to be "pulled" out of the mold are more likely to stick or be distorted during ejection. (See drawing below.)

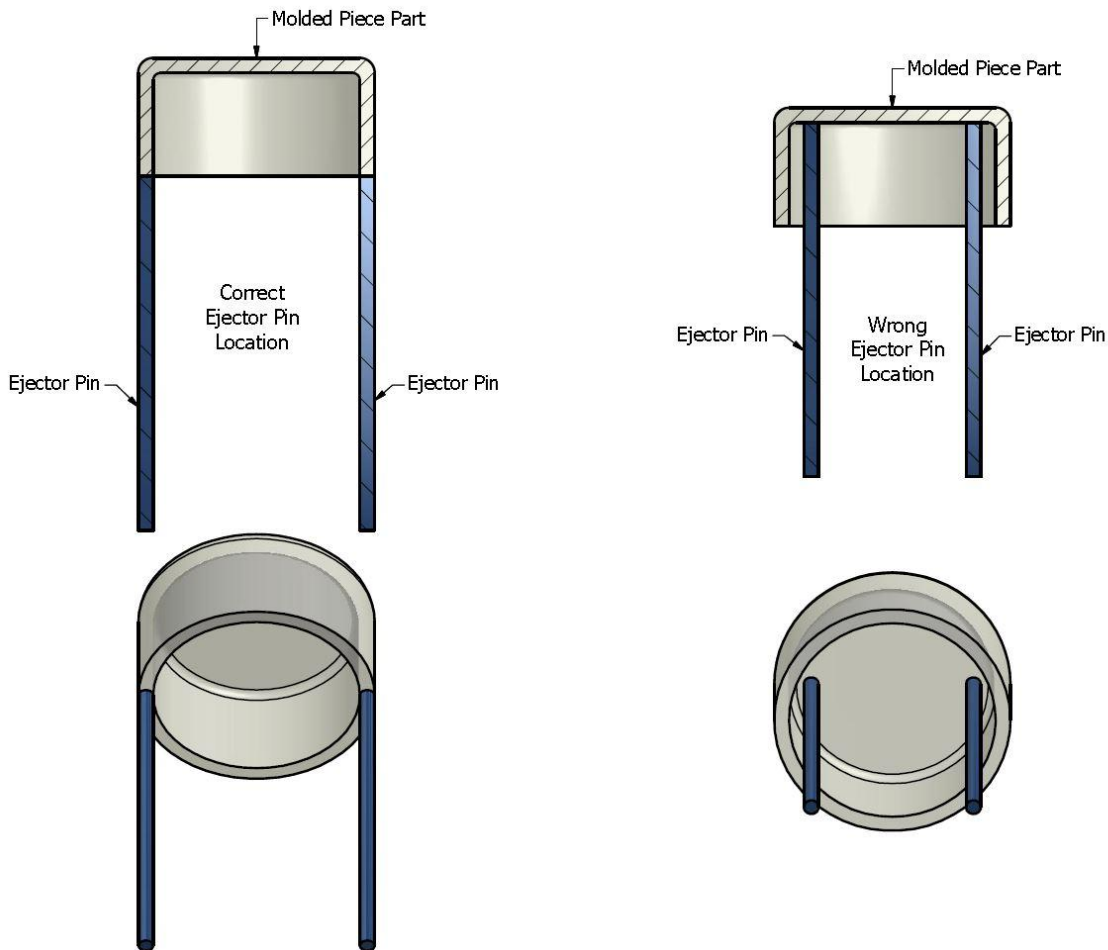

Once the location of the ejector pins is determined, the pin size needs to be decided upon. Very small **diameter ejector pins** can be problematic because of their susceptibility to breaking. Therefore, ejector pins smaller than 3/32" (2.4mm) in diameter are not recommended. Another common problem is material flowing down around the ejector pin and jamming it so it breaks when the ejectors are actuated. To prevent this from happening, the hole for the pin should only be 0.001" (0.025mm) larger than the pin for a depth of 1/2"-5/8" (13mm-16mm) from the cavity. Making it deeper can result in the pin binding and breaking.

To ensure that the ejector plate moves along the centerline of the ejector pins, it is **recommended** that the mold be equipped with a guided ejector system. In addition to aligning the ejectors, the guided ejector system moves the load of the ejector plate and the retainer plate from the ejector pins to the guide pins and bushings of the ejector system. While aligning the ejector holes in the mold with those in the retainer plate is always important, with a guided ejector system the alignment is even more critical.

While it is desirable to have the ejector pins located on flat surfaces, this is not always possible. It is sometimes necessary to locate ejector pins on contoured surfaces. Ejector pins located on contoured surfaces should be made to match the contour of the cavity. It will be necessary to key these pins so they will maintain their alignment with the contour of the cavity.

Polishing and Plating

The trend has been to cut back on **polishing** because of its high cost. While this practice may save money in the construction of the mold, it may increase part costs due to high scrap and down time. Typically, all molding surfaces should be polished to a minimum of an SPI #2 rating. The **mold surfaces to be polished include** the cavities and cores, the vents, and the entire parting line. The reason for polishing the parting line is to insure that any flash that may occur on it will come off the mold with a minimal amount of effort. When polishing a mold, care should be taken to be sure to polish in the direction of draw. Vents need to be polished in the direction of material flow and they should have the same degree of polish as the cavity and core. Flat surfaces that have no influence on the part removal can be polished in any direction. When polishing deep ribs that were cut using the EDM process, it is important to be sure to polish out all of the EDM pit marks. Otherwise, there may be a problem with the rib breaking off from the part and sticking in the mold.

After the mold is completely polished, then it is ready to be **plated**. Please keep in mind that any defect in the steel surface will not be covered by the plating, but will be accentuated by it. While there are a number of different types of plating available, to date, **chrome plated molds** provide the best part release and the best part finish. Because some of our materials have fillers that are incompatible with nickel, the use of nickel or electro less nickel to plate molding surfaces is discouraged. In addition, nickel plating lacks the wear resistance of chrome plating.

The **surfaces to be plated should include** the cores, the cavities, the core pins, and the ends of the ejector pins, the vents, and the entire parting line. To protect the molding surfaces and to insure good part release, it is necessary to plate all the surfaces that were polished. After the mold is plated, it will be necessary to **re-polish** the chrome because unpolished chrome plating may cause sticking.

Center Supports

Often we find that molds built to run thermoset materials have little or no support in the middle. To resolve this problem we suggest installing substantial support pillars down the center of the mold between the parallels 2" (50.8mm) dia. if possible.

High Centering the Mold

Sometimes the center of a mold will have heavy flash even with good center support. In these cases it may be necessary to do what we call “Doming the Mold” or “High Centering the Mold”. This is accomplished by placing a 0.0508mm – 0.0762mm (0.002” or 0.003”) shim on the support pillars in the center of the mold, which will cause the moving side of the mold to be slightly domed.

Side Locks

Any molds where maintaining the alignment of the mold halves is critical to meeting the quality requirements require non tapered side locks. They should be located on all four sides of the mold.